

DC-DC CONVERTER HPC10-W/O

RAILWAY CONVERTER.

FOR PCB MOUNTING

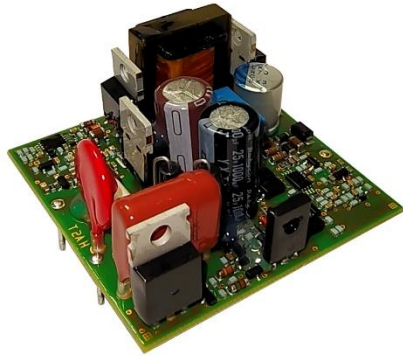

HIGHLIGHTS

- + Output Power up to 10 Watts*
- + Efficiency up to 85 %
- + Ultra Wide Input Range
- + Wide Temperature Range
- + Hold-up-time > 10 ms
- + RoHS compliance
- + According to EN 50155
- + Pins compatible to Quarter Brick

INPUT

Input Voltage Nominal	12, 24, 36, 48, 72, 96 and 110 VDC
Input Voltage Operating	9-137,5 VDC
Input Voltage Range	9-154 VDC (Class 1C)
No Load Input Current	See table page 2, 3, 4
Internal Fusing	2,0 AT***

OUTPUT

Output Voltage	5, 12, 15, 24 V (other outputs on request)
Initial Set Accuracy	<2 %
Minimum Load	No minimum load
Short circuit	Continuous short circuit proof
Line Regulation	<0,5 %
Load Regulation	<1 % (0 % - 100 % load)
Ripple & Noise	<1 % pk-pk, 20 MHz bandwidth
Start Time	<400 ms (@ Vin 12 V) <100 ms (@ Vin 24 V - 110 V)
Max. Output Capacitance	500 µF/A
Temperature Coefficient	<0.01 %/°C

FEATURES

Active Reverse Polarity Protection	Max.160 V
Inrush Current	<1,5 A ² s
Hold-up-time	>10 ms at full load (Class S2 @ Vin 24 V-110 V)

PROTECTION

Over Voltage Protection (OVP)	110-125 % V _{out nom.}
Over Current Protection (OCP)	I _{out nom.} > 105 %. The output switches-off when V _{out nom.} < 90 % and restarts automatically latest after 500 ms of elimination of the overload.
Over Temperature Protection (OTP)	Shutdown at +107 – 112 °C PCB-temp. with about 10 °C hysteresis and auto recovery.

GENERAL

Product Standard	EN 50155:2017
Isolation	2200 VDC Input to Output
Pollution Degree	PD2 according to EN 50124-1:2017
Switching Frequency	Typ. 125 kHz
Dimensions [mm]	55,2 X 54 X 25
Weight	50 g
MTBF / Useful Life Class	3.331.190 h acc. to MIL-HDBK-217F (GB, 45 °C) 2.215.664 h acc. to MIL-HDBK-217F (GB, 60 °C) Class L4 (20 years)
Fire & Smoke	EN 45545-2:2016-02 HL3 (R25)

ENVIRONMENTAL

Operating Ambient Temp.	-40 °C to +70 °C* (Class OT4) and Class ST1, ST2: +15 °C (@ Vin 24 V - 110 V)
Storage Temperature	-40 °C to +85 °C
Rapid Temperature Variation	Class H1
Altitude	up to 2000 m
Vibration / Shock / Bump	EN 61373:2010, Cat. 1B

EMC & SAFETY

EMC Standard	EN 50121-3-2:2016
Emissions	EN 55011: 2018, Class A**
Burst	EN 61000-4-4:2012, level 3 (2 kV), Criteria A
Surge	EN 50121-3-2:2016, line to line ±1 kV, 42R, Criteria A EN 61000-4-5:2014, line to line ± 0,5 kV, Criteria A
Conducted Immunity	EN 61000-4-6:2014, level 3 (10 V), Criteria A
Radiated Immunity	EN 61000-4-3:2006+A1:2008+A2:2010, 20 V/m, Criteria A
Safety	Designed to meet IEC 62368-1:2014 +AC:2015

* Derating by Input Voltage 9 V...12 V see page 6

** In built-in condition the devices may show different EMC properties.

*** Except Version 87 61 12 0052 7

TECHNICAL DATA

For $T_{amb}=25^{\circ}C, V_{in nom}, I_{out nom}$, unless otherwise specified

SPECIFICATION Input 9 - 154 VDC

TYPE		HPC10-W/O							
ORDER NUMBER		87 61 05 0042 9*							
CHARACTERISTIC		Unit							
INPUT	Input Voltage Nominal	V	12V	24	36	48	72	96	110
	Input Voltage Range	V	9...20	14,4...36	21,6...51	28,8...67,2	43,2...101	57,6...134,4	66...154
	Under Voltage Turn-on		<9,0						
	Under Voltage Turn-off	V	<8,0						
	Input Current @ Full Load	A	1,17	0,51	0,33	0,25	0,17	0,13	0,11
	Input Current @ No Load	A	0,025	0,015	0,015	0,01	0,01	0,01	0,01
	Internal Fuse	A	2,0						
				Output					
OUTPUT	Output Voltage Nominal	V	5						
	Output Current Nominal	A	2						
	Output Power	W	10						
	Efficiency @ 6W Load (typical)	%	76	83	84	84	83	83	83
	Efficiency @ 10W Load (typical)	%	72	82	83	83	84	83	82
	Output Current limit	A	2,1...2,6						
	Short Circuit Current (typical)	A	6...10 (pulse approx. 2 Hz)**						
	Transient Response 25 % / 75 % Load Step Recovery Time < 1 ms	mV	±200						

SPECIFICATION Input 9 - 154 VDC

TYPE		HPC10-W/O							
ORDER NUMBER		87 61 12 0042 4							
CHARACTERISTIC		Unit							
INPUT	Input Voltage Nominal	V	12V	24	36	48	72	96	110
	Input Voltage Range	V	9...20	14,4...36	21,6...51	28,8...67,2	43,2...101	57,6...134,4	66...154
	Under Voltage Turn-on		<9,0						
	Under Voltage Turn-off	V	<8,0						
	Input Current @ Full Load	A	1,17	0,51	0,33	0,25	0,17	0,13	0,11
	Input Current @ No Load	A	0,025	0,015	0,015	0,01	0,01	0,01	0,01
	Internal Fuse	A	2,0						
				Output					
OUTPUT	Output Voltage Nominal	V	12						
	Output Current Nominal	A	0,85						
	Output Power	W	10,2						
	Efficiency @ 6W Load (typical)	%	75	82	83	83	83	80	79
	Efficiency @ 10W Load (typical)	%	70	80	83	83	84	83	82
	Output Current limit	A	0,93...1,10						
	Short Circuit Current (typical)	A	4...8 (pulse approx. 2 Hz)**						
	Transient Response 25 % / 75 % Load Step Recovery Time < 1 ms	mV	±200						

* preliminary

** Pulsating current time duration 50 ms

TECHNICAL DATA

For $T_{amb}=25^{\circ}C, V_{in nom}, I_{out nom}$, unless otherwise specified

SPECIFICATION Input 9 - 154 VDC

TYPE		HPC10-W/O							
ORDER NUMBER		87 61 12 0052 7							
CHARACTERISTIC		Unit							
INPUT	Input Voltage Nominal	V	12V	24	36	48	72	96	110
	Input Voltage Range	V	9...20	14,4...36	21,6...51	28,8...67,2	43,2...101	57,6...134,4	66...154
	Under Voltage Turn-on		<9,0						
	Under Voltage Turn-off	V	<8,0						
	Input Current @ Full Load	A	1,17	0,51	0,33	0,25	0,17	0,13	0,11
	Input Current @ No Load	A	0,025	0,015	0,015	0,01	0,01	0,01	0,01
	Internal Fuse**	A	no Fuse						
OUTPUT			Output						
	Output Voltage Nominal	V	12						
	Output Current Nominal	A	0,85						
	Output Power	W	10,2						
	Efficiency @ 6W Load (typical)	%	75	82	83	83	83	80	79
	Efficiency @ 10W Load (typical)	%	70	80	83	83	84	83	82
	Output Current limit	A	0,93...1,10						
	Short Circuit Current (typical)	A	4...8 (pulse approx. 2 Hz)*						
	Transient Response 25 % / 75 % Load Step Recovery Time < 1 ms	mV	±200						

SPECIFICATION Input 9 - 154 VDC

TYPE		HPC10-W/O							
ORDER NUMBER		87 61 15 0042 1							
CHARACTERISTIC		Unit							
INPUT	Input Voltage Nominal	V	12V	24	36	48	72	96	110
	Input Voltage Range	V	9...20	14,4...36	21,6...51	28,8...67,2	43,2...101	57,6...134,4	66...154
	Under Voltage Turn-on		<9,0						
	Under Voltage Turn-off	V	<8,0						
	Input Current @ Full Load	A	1,17	0,51	0,33	0,25	0,17	0,13	0,11
	Input Current @ No Load	A	0,025	0,015	0,015	0,01	0,01	0,01	0,01
	Internal Fuse	A	2,0						
OUTPUT			Output						
	Output Voltage Nominal	V	15						
	Output Current Nominal	A	0,67						
	Output Power	W	10						
	Efficiency @ 6W Load (typical)	%	76	83	84	84	83	80	79
	Efficiency @ 10W Load (typical)	%	72	83	85	85	85	83	82
	Output Current limit	A	0,73...0,85						
	Short Circuit Current (typical)	A	4...8 (pulse approx. 2 Hz)*						
Transient Response 25 % / 75 % Load Step Recovery Time < 1 ms	mV	±200							

* Pulsating current time duration 50 ms

** external Fuse 2ATH necessary

TECHNICAL DATA

For $T_{amb}=25^{\circ}C, V_{in nom}, I_{out nom}$, unless otherwise specified

SPECIFICATION Input 9 - 154 VDC

TYPE		HPC10-W/O							
ORDER NUMBER		87 61 24 0042 9*							
CHARACTERISTIC		Unit							
INPUT	Input Voltage Nominal	V	12V	24	36	48	72	96	110
	Input Voltage Range	V	9...20	14,4...36	21,6...51	28,8...67,2	43,2...101	57,6...134,4	66...154
	Under Voltage Turn-on		<9,0						
	Under Voltage Turn-off	V	<8,0						
	Input Current @ Full Load	A	1,17	0,51	0,33	0,25	0,17	0,13	0,11
	Input Current @ No Load	A	0,025	0,015	0,015	0,01	0,01	0,01	0,01
	Internal Fuse	A	2,0						
OUTPUT			Output						
	Output Voltage Nominal	V	24						
	Output Current Nominal	A	0,42						
	Output Power	W	10						
	Efficiency @ 6W Load (typical)	%	76	83	84	84	83	83	83
	Efficiency @ 10W Load (typical)	%	72	82	83	83	84	83	82
	Output Current limit	A	0,46...0,55						
	Short Circuit Current (typical)	A	4...8 (pulse approx. 2 Hz)**						
Transient Response 25 % / 75 % Load Step Recovery Time < 1 ms	mV	±200							

* preliminary

** Pulsating current time duration 50 ms

TECHNICAL DATA

For $T_{amb}=25^{\circ}C, V_{in nom}, I_{out nom}$, unless otherwise specified

MECHANICAL DETAILS

1. Dimensions in mm
2. Unless otherwise specified, general tolerances +/- 0,5 are for values in brackets (XX)
Values not in brackets are according to ISO-2768-1m.

Coating Class PC2: Lackwerke Peters ELPEGUARD SL 1307-FLZ/2
Protection Degree: IP00

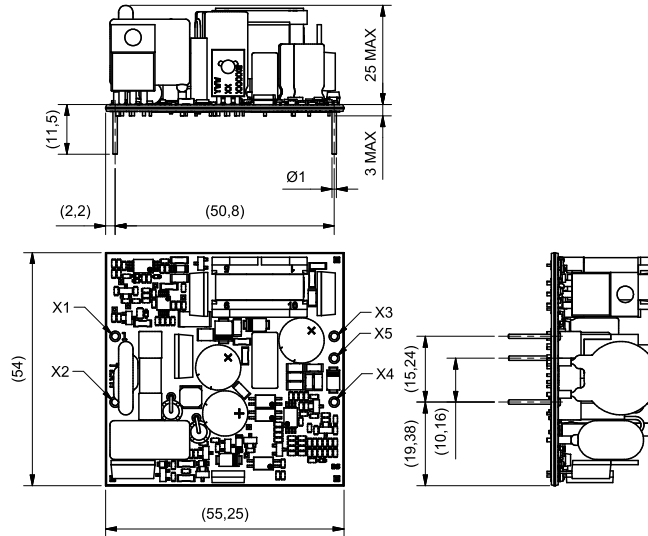

Production acc. to IPC-A-610 (exception bonding)

PINNING

Pin	Function	
X1	+Vin	Positive Input Voltage
X2	-Vin	Negative Input Voltage
X3	+Vout	Positive Output Voltage
X4	-Vout	Negative Output Voltage
X5	n.c.	Not connected

NOTES

Installation instructions:

The converters have to be installed according to the guidelines currently in force, like other open electronic component assemblies. Attention must be paid to sufficient ventilation, carry off heat, fastening and protection against accidental contact. Fault protection: The converters are equipped with a soldered-in-time-lag fuse corresponding to IEC 60127-2 for input protection, except version 87 61 12 0052 7. In case at fault the supplying current source must be capable to blow the fuse.

Caution

1. No protection against touching, dangerous voltage
2. After power off, wait 10 s before disconnecting or touching

BLOCK DIAGRAM

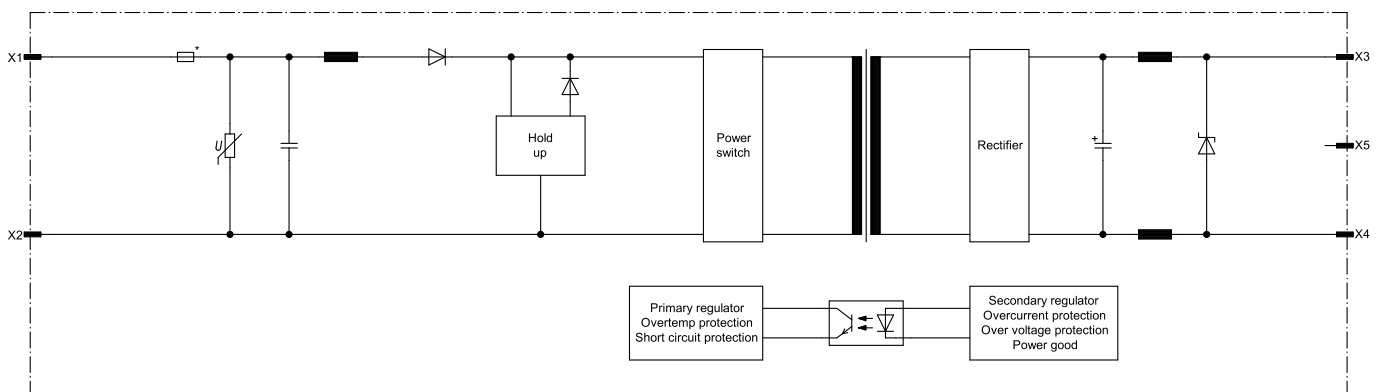

* not for Version 87 61 12 0052 7

DESCRIPTION OF FEATURES

Output Power Derating

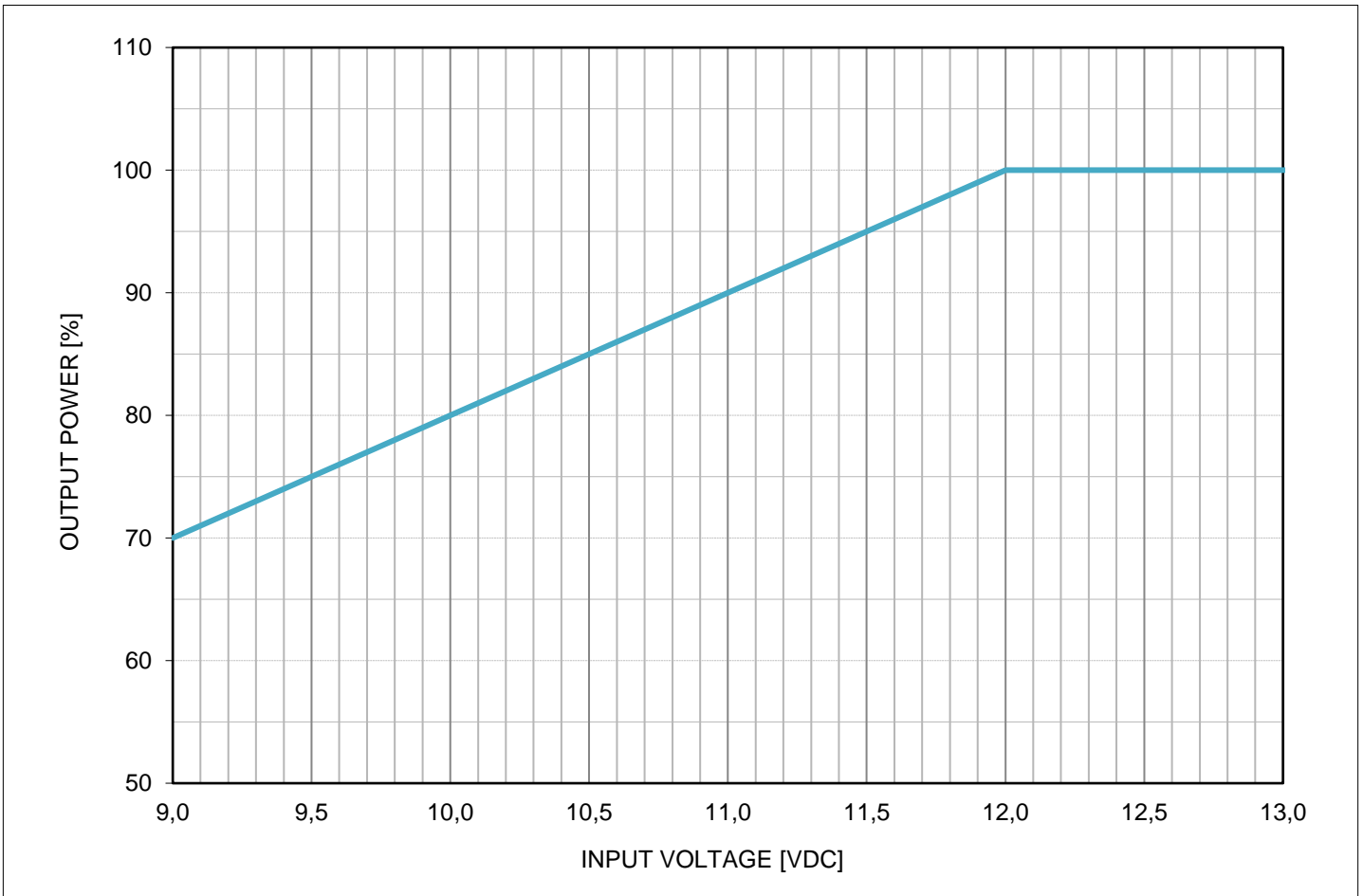

CHANGE HISTORY

Revision	Date	Author	Modification
a00	2020-10-13	A. Ehrhardt	First edition
a01	2021-07-01	A. Ehrhardt	MTBF defined