



## 40A DC UPS Module

## DR-UPS40



## ■ Features :

- Battery controller for DIN Rail UPS system
- Parallel connection to DC BUS
- Suitable for 24V system up to 40A
- Installed on DIN Rail TS35 / 7.5 or 15
- Built-in battery test function
- Battery polarity protection
- Relay contact signal output and LED indicator for DC BUS OK, Battery Fail, and Battery Discharge
- Cooling by free air convection
- 3 years warranty



## SPECIFICATION

| MODEL                  |  | DR-UPS40  |
|------------------------|--|---|
| DC INPUT / DC BUS      | DC VOLTAGE (Typ.) Note.5   | 24 ~ 29V  |
|                        | RATED CURRENT  | 40A   |
| BATTERY INPUT / OUTPUT | VOLTAGE RANGE (Typ.)   | 21 ~ 29V  |
|                        | CURRENT RANGE  | 0 ~ 40A   |
|                        | CHARGE CURRENT (Typ.) Note.4   | 2A  |
|                        | EXTERNAL BATTERY (Typ.)  | 4 / 7 / 12AH / 24V  |
| FUNCTION               | RELAY CONTACT RATING (max.)  | 30VDC, 1A   |
|                        | DC BUS OK  | Relay contact : Short when DC voltage between 21~29V( $\pm 3\%$ ), relay contacts<br>LED(Green) : DC BUS OK : light ; DC BUS fail : dark  |
|                        | BATTERY FAIL Note.2  | Short when battery voltage falls below 21.9V( $\pm 3\%$ ) or battery failure is observed through the battery test function, relay contacts<br>LED(Red) : Battery over-discharge warning or battery broken : light ; Battery OK : dark |
|                        | BATTERY DISCHARGE  | Relay contact : Short when battery in discharge condition, relay contacts<br>LED(Yellow):light : Battery discharging ; dark : Battery is not discharging or discharging current<2.0A  |
| ENVIRONMENT            | WORKING TEMP.  | -20 ~ +70°C   |
|                        | WORKING HUMIDITY   | 20 ~ 90% RH   |
|                        | STORAGE TEMP., HUMIDITY  | -20 ~ +85°C, 10 ~ 95% RH  |
|                        | VIBRATION  | Component : 10 ~ 500Hz, 2G 10min./1cycle, 60min. each X, Y, Z axes ; Mounting : Compliance to IEC600068-2-6   |
| SAFETY & EMC (Note 3)  | WITHSTAND VOLTAGE  | Terminal-Chassis :0.5KVAC, Relay Contacts-Terminal :0.5KVAC   |
|                        | ISOLATION RESISTANCE   | Terminal-Chassis :>100M Ohms / 500VDC / 25°C / 70% RH   |
|                        | EMC EMISSION   | Compliance to EN55032 (CISPR32) Class B, EN61000-3-2,-3, EAC TP TC 020  |
|                        | EMC IMMUNITY   | Compliance to EN61000-4-2,3,4,5,6,8,11, heavy industry level, criteria A, EAC TP TC 020   |
| OTHERS                 | MTBF   | 161.9K hrs min. MIL-HDBK-217F (25°C)  |
|                        | DIMENSION  | 55.5*125.2*100mm (W*H*D)  |
|                        | PACKING  | 0.55Kg; 20pcs/12Kg/1.29CUFT   |
| NOTE                   | <ol style="list-style-type: none"> <li>1. All parameters NOT specially mentioned are measured at rated load and 25°C of ambient temperature.</li> <li>2. Battery fail will only function at UPS mode with battery connected. Every 25 seconds, unit will send out test signal through "Battery Fail" relay contact and LED indicator once the battery is fail.</li> <li>3. The power supply is considered a component which will be installed into a final equipment. All the EMC tests are been executed by mounting the unit on a 360mm*360mm metal plate with 1mm of thickness. The final equipment must be re-confirmed that it still meets EMC directives. For guidance on how to perform these EMC tests, please refer to "EMI testing of component power supplies." (as available on <a href="http://www.meanwell.com">http://www.meanwell.com</a>)</li> <li>4. Battery charging will be in progress when DC input &gt; battery voltage.</li> <li>5. DR-UPS40 will be in operation when DC input is applied at the beginning.</li> <li>6. The ambient temperature derating of 3.5°C/1000m with fanless models and of 5°C/1000m with fan models for operating altitude higher than 2000m(6500ft).</li> </ol> |   |



40A DC UPS Module

# DR-UPS40

## Mechanical Specification

Case No.923D Unit:mm

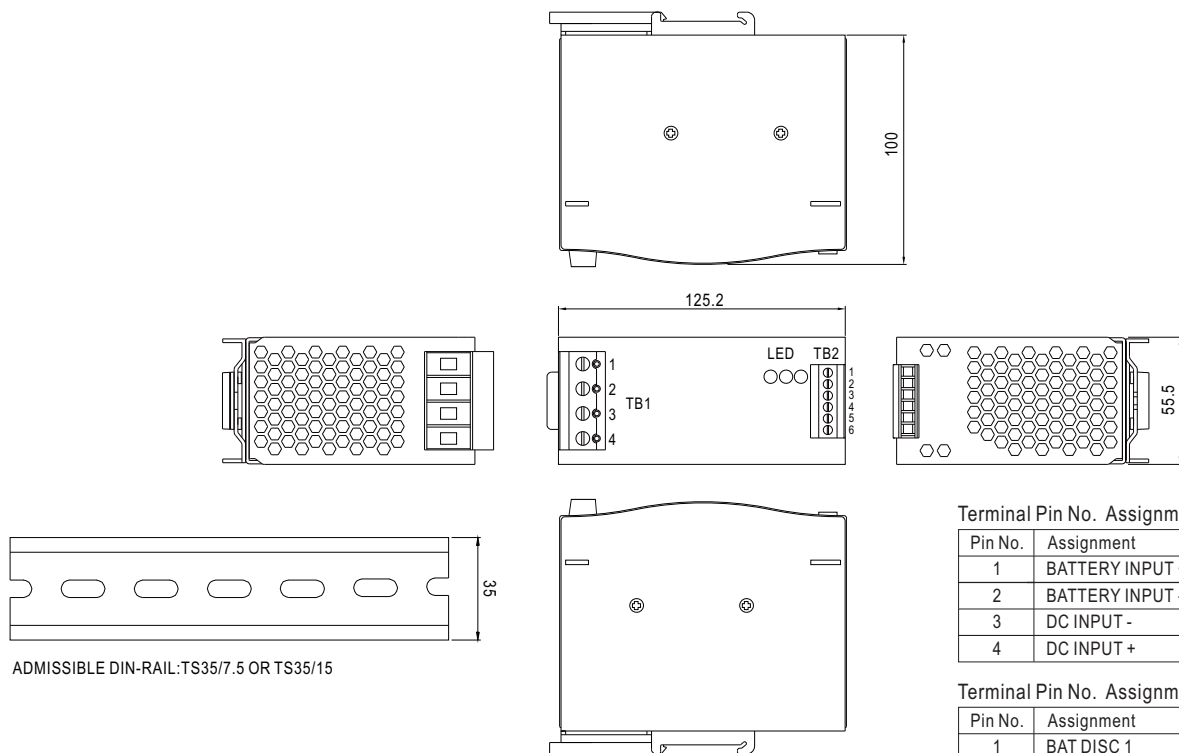

ADMISSIBLE DIN-RAIL: TS35/7.5 OR TS35/15

Terminal Pin No. Assignment (TB1)

| Pin No. | Assignment      |
|---------|-----------------|
| 1       | BATTERY INPUT + |
| 2       | BATTERY INPUT - |
| 3       | DC INPUT -      |
| 4       | DC INPUT +      |

Terminal Pin No. Assignment (TB2)

| Pin No. | Assignment |
|---------|------------|
| 1       | BAT DISC 1 |
| 2       | BAT DISC 2 |
| 3       | BAT FAIL 1 |
| 4       | BAT FAIL 2 |
| 5       | DC OK 1    |
| 6       | DC OK 2    |

## Block Diagram

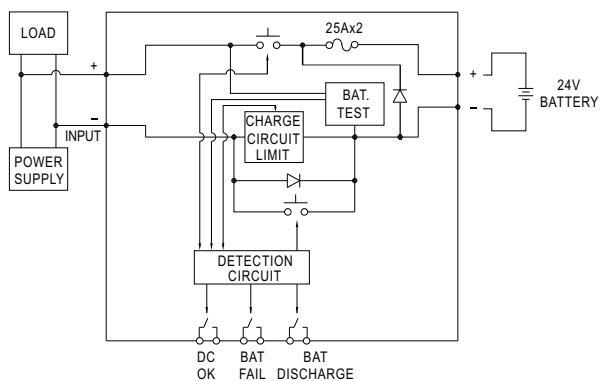

## Derating Curve

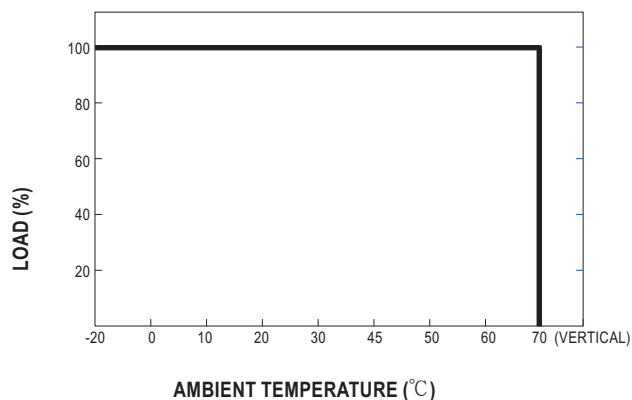

## ■ Suggested Application

### 1. Back up connection for AC interruption

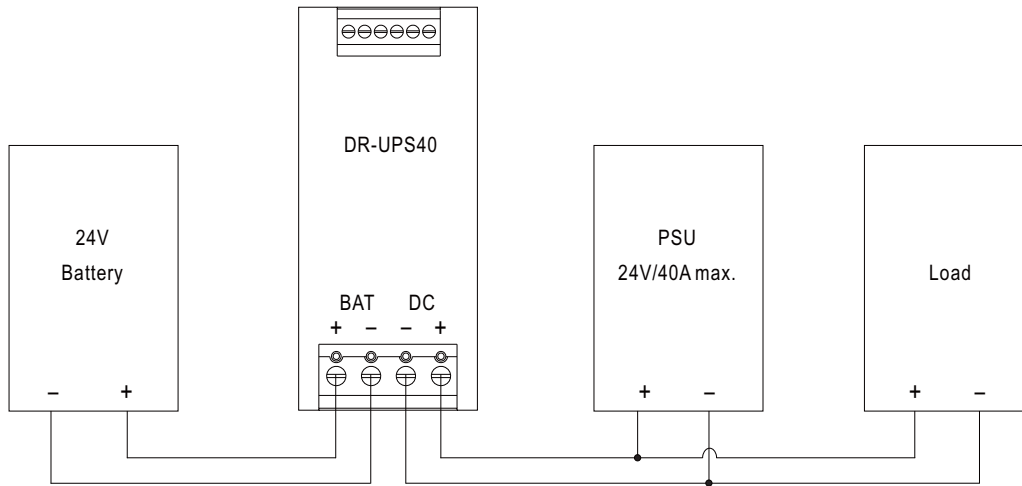

### 2. Combine redundancy module (DR-RDN20) to back up AC interruption or failure of PSU

